

10Gb/s 1310nm Single-mode SFP+ Transceiver



PRODUCT FEATURES

- Up to 11.1Gbps Data Links
- 1310nm DFB transmitter, PIN photo-detector
- Up to 10km transmission on SMF
- Duplex LC connector
- Metal enclosure, for lower EMI
- Electrical interface compliant to SFF-8431
- Compliant with SFP+ MSA with LC connector
- 2-wire interface for management
- Specifications compliant with SFF 8472
- Single 3.3V power supply
- Power dissipation < 1.2W
- Case operating temperature range: Commercial: 0°C to +70°C
Industrial: -40°C to +85°C

APPLICATIONS

- 10GBASE-LR/LW 10G Ethernet

STANDARD

- Compliant with SFF-8472 SFP+ MSA.
- Compliant to SFP+ SFF-8431 and SFF-8432.
- Compliant to 802.3ae 10GBASE-LR.
- RoHS Compliant.

Absolute Maximum Ratings

Parameter	Symbol	Min	Typ	Max	Unit	Ref.
Maximum Supply Voltage	V _{cc}	-0.5		4.7	V	
Storage Temperature	TS	-40		85	°C	
Case Operating Temperature	T _{case}	-5		70	°C	

Electrical Characteristics (T_{case} = -5 to 70°C, V_{CC} = 3.14 to 3.46 Volts)

Parameter	Symbol	Min	Typ	Max	Unit	Ref.
Supply Voltage	V _{cc}	3.14	3.3	3.46	V	
Supply Current	I _{cc}			350	mA	
Transmitter						
Input differential impedance	R _{in}		100		Ω	1
Single ended data input swing	V _{in,pp}	180		700	mV	
Transmit Disable Voltage	VD	V _{cc} -1.3		V _{cc}	V	
Transmit Enable Voltage	VEN	V _{ee}		V _{ee} + 0.8	V	2
Transmit Disable Assert Time				10	us	
Receiver						
Differential data output swing	V _{out,pp}	300		850	mV	3
Data output rise time	t _r	28			ps	4
Data output fall time	t _f	28			ps	4
LOS Fault	V _{LOS fault}	V _{cc} -1.3		V _{cc} HOS T	V	5
LOS Normal	V _{LOS norm}	V _{ee}		V _{ee} +0.8	V	5
Power Supply Rejection	PSR	100			mVp p	6

Notes:

1. Connected directly to TX data input pins. AC coupled thereafter.
2. Or open circuit.
3. Into 100 ohms differential termination.
4. 20 – 80 %.
5. Loss Of Signal is LVTTTL. Logic 0 indicates normal operation; logic 1 indicates no signal detected.
6. Receiver sensitivity is compliant with power supply sinusoidal modulation of 20 Hz to 1.5 MHz up to specified value applied through the recommended power supply filtering network.

Optical Characteristics (T_{case} = -5 to 70°C, V_{CC} = 3.14 to 3.46 Volts)

Parameter	Symbol	Min	Typ	Max	Unit	Ref
Transmitter						
Output Opt. Pwr	P _{OUT}	-6		-0.5	dBm	1
Optical Wavelength	λ	1260	1310	1355	nm	
Spectral Width (-20dB)	σ			1	nm	
Side mode suppression ratio	SMSR	30			dB	
Optical Extinction Ratio	ER	3.5			dB	
Output Eye Mask	Compliant with IEEE 0802.3ae					
Receiver						
Rx Sensitivity	R _{SENS}			-14.4	dBm	2
Input Saturation Power (Overload)	P _{sat}	0.5			dBm	
Wavelength Range	λ_c	1270		1610	nm	
LOS De -Assert	LOSD			-17	dBm	
LOS Assert	LOSA	-30			dBm	
LOS Hysteresis		0.5	1.0		dB	

Notes:

1. Class 1 Laser Safety per FDA/CDRH and IEC-825-1 regulations.
2. With worst-case extinction ratio. Measured with a PRBS $2^{31}-1$ test pattern, @10.325Gb/s, BER < 10^{-12} .

Pin Assignment

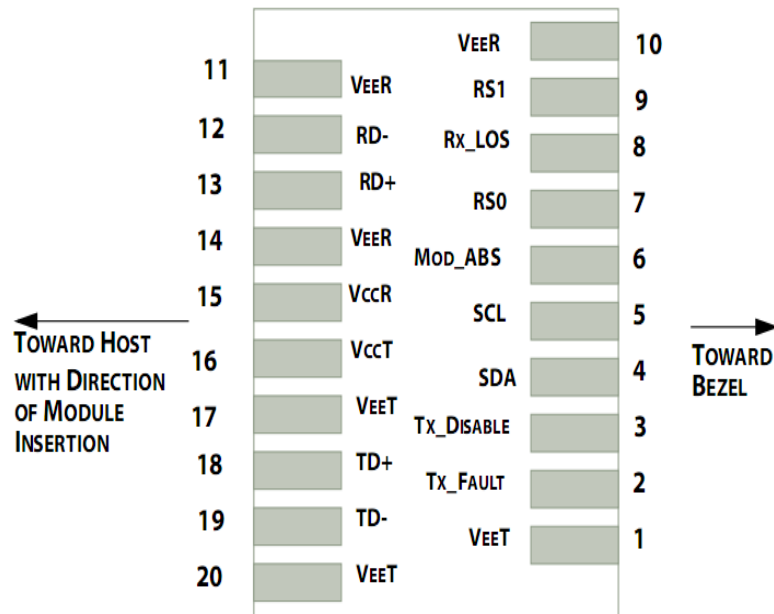

Pin out of Connector Block on Host Board

Pin	Symbol	Name/Description	Ref
1	V_{EET}	Transmitter Ground (Common with Receiver Ground)	1
2	T_{FAULT}	Transmitter Fault.	2
3	T_{DIS}	Transmitter Disable. Laser output disabled on high or open.	3
4	SDA	2-wire Serial Interface Data Line	4
5	SCL	2-wire Serial Interface Clock Line	4
6	MOD_ABS	Module Absent. Grounded within the module	4
7	RS0	Rate Select 0	5
8	LOS	Loss of Signal indication. Logic 0 indicates normal operation.	6
9	RS1	No connection required	1
10	V_{EER}	Receiver Ground (Common with Transmitter Ground)	1
11	V_{EER}	Receiver Ground (Common with Transmitter Ground)	1
12	RD-	Receiver Inverted DATA out. AC Coupled	
13	RD+	Receiver Non-inverted DATA out. AC Coupled	
14	V_{EER}	Receiver Ground (Common with Transmitter Ground)	1
15	V_{CCR}	Receiver Power Supply	
16	V_{CCT}	Transmitter Power Supply	
17	V_{EET}	Transmitter Ground (Common with Receiver Ground)	1
18	TD+	Transmitter Non-Inverted DATA in. AC Coupled.	
19	TD-	Transmitter Inverted DATA in. AC Coupled.	
20	V_{EET}	Transmitter Ground (Common with Receiver Ground)	1

Notes:

1. Circuit ground is internally isolated from chassis ground.
2. T_{FAULT} is an open collector/drain output, which should be pulled up with a 4.7k – 10k Ohms resistor on the host board if intended for use. Pull up voltage should be between 2.0V to $V_{cc} + 0.3V$. A high output indicates a transmitter fault caused by either the TX bias current or the TX output power exceeding the

preset alarm thresholds. A low output indicates normal operation. In the low state, the output is pulled to <math><0.8\text{V}</math>.

3. Laser output disabled on $T_{\text{DIS}} > 2.0\text{V}$ or open, enabled on $T_{\text{DIS}} < 0.8\text{V}$.
4. Should be pulled up with $4.7\text{k}\Omega$ - $10\text{k}\Omega$ host board to a voltage between 2.0V and 3.6V . MOD_ABS pulls line low to indicate module is plugged in.
5. Internally pulled down per SFF-8431 Rev 4.1.
6. LOS is open collector output. It should be pulled up with $4.7\text{k}\Omega$ – $10\text{k}\Omega$ on host board to a voltage between 2.0V and 3.6V . Logic 0 indicates normal operation; logic 1 indicates loss of signal.

Digital Diagnostic Functions

SFP-10G-LR transceivers support the 2-wire serial communication protocol as defined in the SFP MSA1.

The standard SFP serial ID provides access to identification information that describes the transceiver's capabilities, standard interfaces, manufacturer, and other information.

Additionally, SFP+ transceivers provide a unique enhanced digital diagnostic monitoring interface, which allows real-time access to device operating parameters such as transceiver temperature, laser bias current, transmitted optical power, received optical power and transceiver supply voltage. It also defines a sophisticated system of alarm and warning flags, which alerts end-users when particular operating parameters are outside of a factory set normal range.

The SFP MSA defines a 256-byte memory map in EEPROM that is accessible over a 2-wire serial interface at the 8 bit address 1010000X (A0h). The digital diagnostic monitoring interface makes use of the 8 bit address 1010001X (A2h), so the originally defined serial ID memory map remains unchanged.

The operating and diagnostics information is monitored and reported by a Digital Diagnostics Transceiver Controller (DDTC) inside the transceiver, which is accessed through a 2-wire serial interface. When the serial protocol is activated, the serial clock signal (SCL, Mod Def 1) is generated by the host. The positive edge clocks data into the SFP transceiver into those segments of the E2PROM that are not write-protected. The negative edge clocks data from the SFP transceiver. The serial data signal (SDA, Mod Def 2) is bi-directional for serial data transfer. The host uses SDA in conjunction with SCL to mark the start and end of serial protocol activation. The memories are organized as a series of 8-bit data words that can be addressed individually or sequentially.

Host - Transceiver Interface Block Diagram

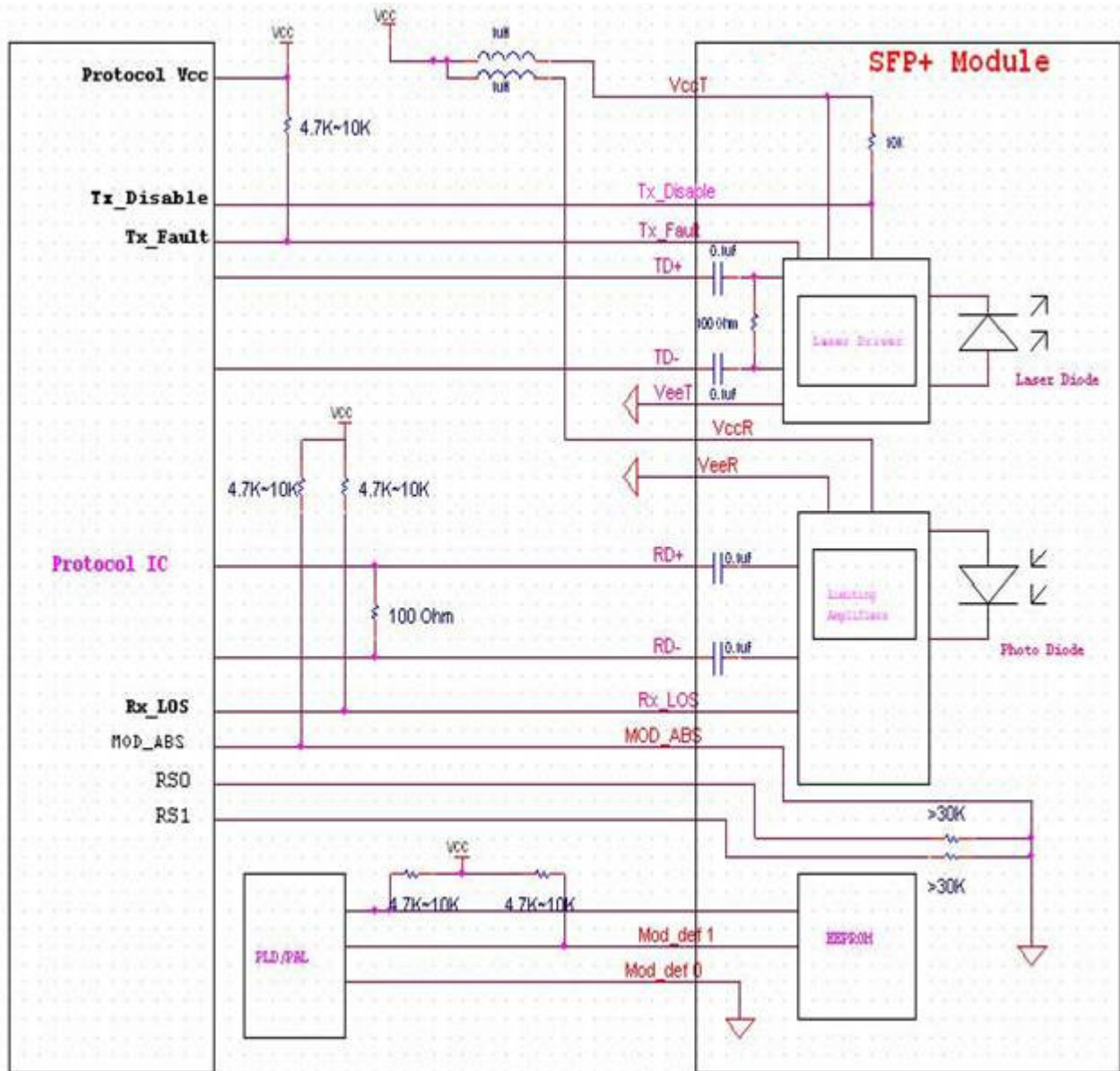

Outline Dimensions

Comply to SFF-8432 rev. 5.0, the improved Pluggable form factor specification.

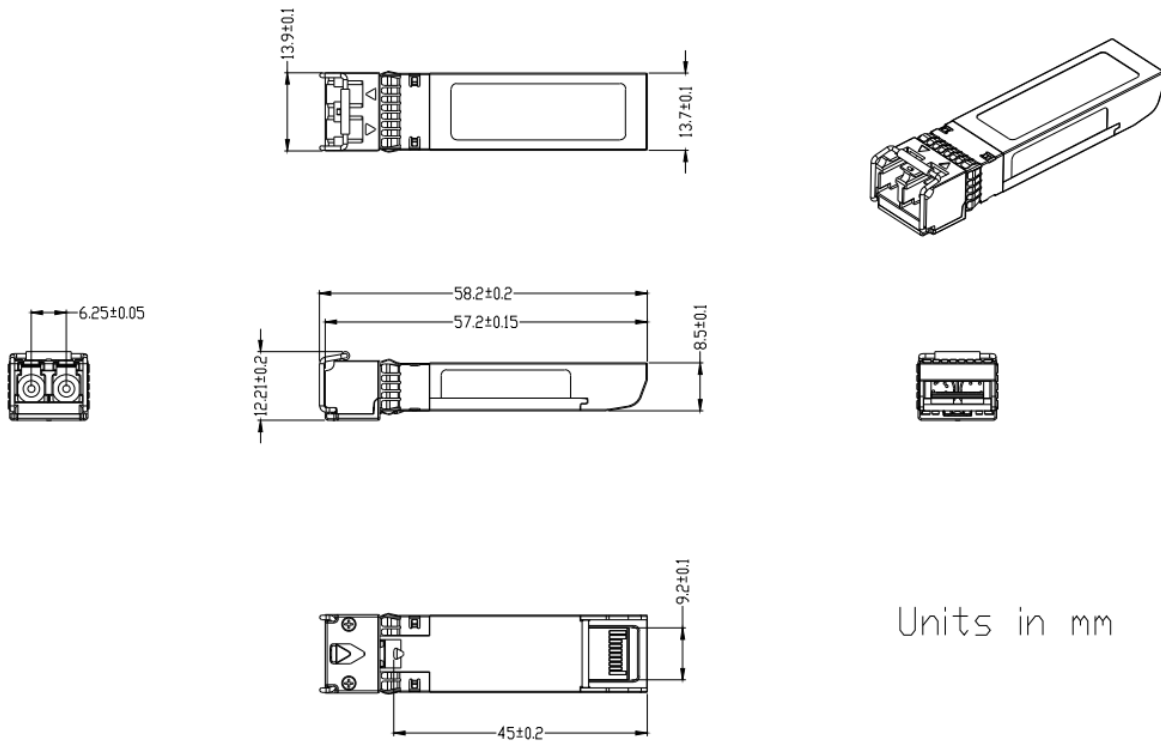

Units in mm

Regulatory Compliance

Feature	Reference	Performance
Electrostatic discharge (ESD)	IEC/EN 61000-4-2	Compatible with standards
Electromagnetic Interference (EMI)	FCC Part 15 Class B EN 55022 Class B (CISPR 22A)	Compatible with standards
Laser Eye Safety	FDA 21CFR 1040.10, 1040.11 IEC/EN 60825-1, 2	Class 1 laser product
Component Recognition	IEC/EN 60950, UL	Compatible with standards
ROHS	2002/95/EC	Compatible with standards
EMC	EN61000-3	Compatible with standards