

## QSFP28100Gb/sLR410kmDDMTransceiver



### PRODUCTFEATURES

- Supportlineratesfrom103.125Gbps;
- Transmissiondatarateupto25.78 (NRZ) perchannel;
- Upto10kmtransmissiononsinglemodefiber;
- HighspeedI/Oelectricalinterface(CAUI-4);
- I2CinterfacewithintegratedDigitalDiagnosticmonitoring;
- QSFP28MSApackagewithduplexLCconnector;
- Single+3.3Vpowersupply;Dissipation:
- Commercial(0~70): <3.5W
- ComplieswithEUDirective2015/863/EU;

### APPLICATIONS

- 100GBASE-CWDM4Ethernet
- 100GDatacom&Telecomconnections

## DESCRIPTIONS

100G QSFP LR4 Transceiver is designed for 10km optical communication applications. This module contains 4-lane optical transmitter, 4-lane optical receiver and module management block including 2 wire serial inter-face. The optical signals are multiplexed to a single-mode fiber through an industry standard LC connector.

## ModuleBlockDiagram

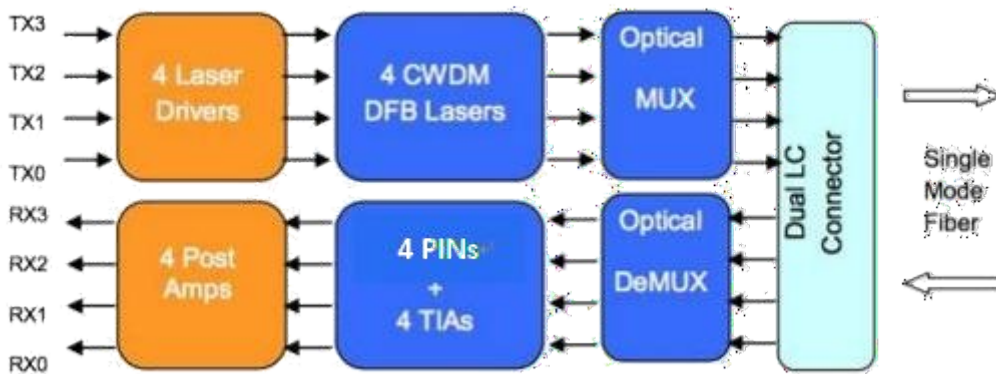

## AbsoluteMaximumRatings

Parameter	Symbol	Min.	Max.	Unit
Storage Temperature	TS	-40	+85	°C
MaximumSupplyVoltage	VCC	-0.5	3.6	V
OperatingRelative Humidity	RH		85	%

## RecommendedOperatingConditions

Parameter	Symbol	Min.	Typical	Max.	Unit	Notes
OperatingCase Temperature	Top	0		+70	°C	
PowerSupplyVoltage	V <sub>CC</sub>	3.13	3.3	3.47	V	
PowerSupplyCurrent	I <sub>CC</sub>			1.06	A	
MaximumPower Dissipation	P <sub>D</sub>			3.5	W	
AggregateBitRate	BR <sub>AVE</sub>		103.125		Gb/s	
LaneBitRate	BR <sub>LANE</sub>		25.78125		Gb/s	
TransmissionDistance	TD			10	km	
Coupled fiber	Singlemode fiber					9/125um SMF

## Electrical Characteristics

Parameter	Symbol	Min.	Typical	Max.	Unit	Notes
<b>Transmitter(ModuleInput)</b>						
DataRate,eachlane			25.78125		Gbps	
DifferentialVoltagepk-pk	Vpp			900	mV	1
CommonModeVoltage	Vcm	-350		2850	mV	
Transitiontime	Trise/Tfall	10			ps	2
<b>Receiver(ModuleOutput)</b>						
DataRate,eachlane			25.78125		Gbps	
CommonModeNoise,RMS	Vrms			17.5	mV	
Differentialoutputvoltage swing	Vout,pp			900	mV	
Eye width	EW15	0.57			UI	
Eyeheight	EH15	228			mV	
DifferentialTerminationResistance Mismatch				10	%	1
Transitiontime	Trise/Tfall	12			ps	

## Optical Characteristics

Parameter	Symbol	Min.	Typical	Max.	Unit	Notes
<b>Transmitter</b>						
SignalingSpeedperLane			25.78125		Gbps	
LaneWavelength	L0	1264.5	1271	1277.5	nm	
	L1	1284.5	1291	1297.5	nm	
	L2	1304.5	1311	1317.5	nm	
	L3	1324.5	1331	1337.5	nm	
TotalAverageLaunch Power	P <sub>T</sub>			8.5	dBm	1
AverageLaunchPowerperLane,	P <sub>avg</sub>	-6.5		2.5	dBm	1
OMA,eachLane	P <sub>OMA</sub>	-4		2.5	dBm	1
Differenceinlaunchpower betweenanytwolanes(Average	P <sub>tx,diff</sub>			3	dB	

andOMA)betweenanyTwo Lanes(OMA)						
AverageOutputPower(Laser Turnoff)	P <sub>off</sub>			-30	dBm	
SideModeSuppressionRatio	SMSR	30			dB	
ExtinctionRatio	ER	3.5			dB	
RIN <sub>20OMA</sub>	RIN			-130	dB/Hz	
OpticalReturnLossTolerance	TOL			20	dB	
TransmitterReflectance	R <sub>T</sub>			-12	dB	
OpticalEyeMask	{0.25,0.4,0.45,0.25,0.28,0.4}				%	2
Receiver						
Signalingrate,eachlane			25.78125		Gbps	
CenterWavelengthLane0	λ <sub>0</sub>	1264.5	1271	1277.5	nm	
CenterWavelengthLane1	λ <sub>1</sub>	1284.5	1291	1297.5	nm	
CenterWavelengthLane2	λ <sub>2</sub>	1304.5	1311	1317.5	nm	
CenterWavelengthLane3	λ <sub>3</sub>	1324.5	1331	1337.5	nm	
Damagethreshold,each lane	P <sub>damage</sub>	3.5			dBm	
AverageReceivePower,each lane		-11.5		2.5	dBm	
ReceiverSensitivity(OMA)per Lane	SEN			-10	dBm	3
LosAssert	LosA	-30			dBm	
LosDe-assert	LosDA			-12	dBm	
LosHysteresis	LosH	0.5			dB	

Note:

1. TheopticalpowerislaunchedintoSMF.
2. MeasuredwithaPRBS2<sup>31</sup>-1testpattern@25.78125,Hitratio≤5E-5.
3. MeasuredwithaPRBS2<sup>31</sup>-1testpattern@25.78125Gb/s,BER≤1E-12.

## Pin Diagram

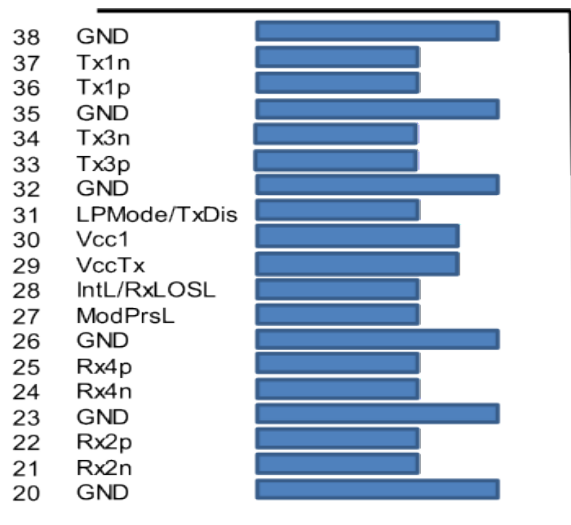

Top Side  
Viewed From Top

Module Card Edge

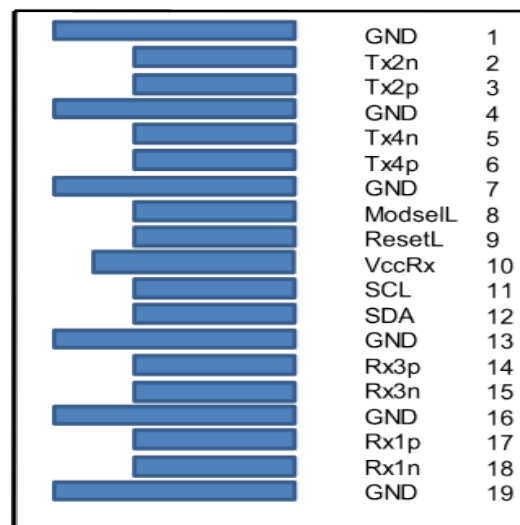

Bottom Side  
Viewed From Bottom

# Recommended Interface Circuit

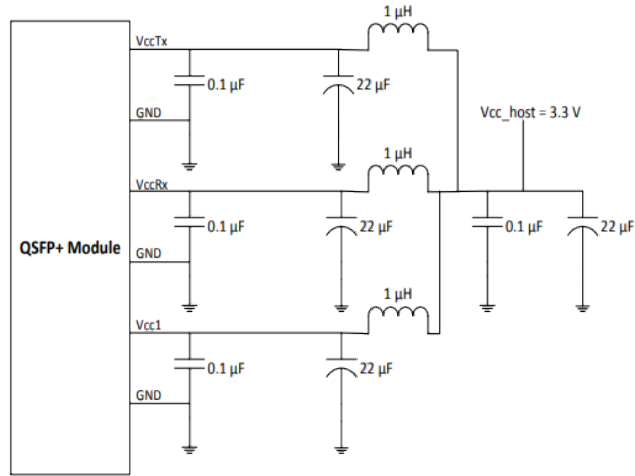

FIGURE 5-4 RECOMMENDED HOST BOARD POWER SUPPLY FILTERING

# Mechanical Diagram

