

10G SFP+ SR 850nm MM 300m DDM LC



Features:

- ❖ Optical interface compliant to IEEE 802.3ae
- ❖ Electrical interface compliant to SFF-8431
- ❖ Hot Pluggable
- ❖ 850nm VCSEL transmitter, PIN photo-detector
- ❖ Maximum link length of 300m on MMF
- ❖ Operating case temperature: 0 to 70 °C
- ❖ Low power consumption
- ❖ Maximum link length of 300m on MMF
- ❖ All-metal housing for superior EMI performance
- ❖ Advanced firmware allow customer system encryption information to be stored in transceiver
- ❖ Cost effective SFP+ solution, enables higher port densities and greater bandwidth
- ❖ RoHS6 compliant (lead free)

Applications:

- ❖ 10GBASE-SR at 10.3125Gbps
- ❖ 10GBASE-SW at 9.953Gbps
- ❖ Other optical links

Part Number Ordering Information

10G-SFP-SR	SFP+ 10Gbs300m Tx850nm MMF LC DDM
-------------------	-----------------------------------

Description:

This 850nm VCSEL10Gigabit SFP+ transceiver is designed to transmit and receive optical data over 50/125µm or 62.5/125µm multimode optical fiber (Table 1).

Fiber type	Minimum modal bandwidth @ 850 nm (MHz*km)	Operating range (meters)
62.5 µm MMF	160	2 to 26
	200	2 to 33
50 µm MMF	400	2 to 66
	500	2 to 82
	2000	2 to 300

Table 1: SFP+ SR Operating Range for each Optical Fiber Type

The SFP+ SR module electrical interface is compliant to SFI electrical specifications. The transmitter input and receiver output impedance is 100 Ohms differential. Data lines are internally AC coupled.

The module provides differential termination and reduce differential to common mode conversion for quality signal termination and low EMI. SFI typically operates over 200 mm of improved FR4 material or up to about 150mm of standard FR4 with one connector.

The transmitter converts 10Gbit/s serial PECL or CML electrical data into serial optical data compliant with the 10GBASE-SR standard. An open collector compatible Transmit Disable (Tx_Dis) is provided. Logic “1” or no connection on this pin will disable the laser from transmitting. Logic “0” on this pin provides normal operation. The transmitter has an internal automatic power control loop (APC) to ensure constant optical power output across supply voltage and temperature variations. An open collector compatible Transmit Fault (TFault) is provided. TX_Fault is a module output contacts that when high, indicates that the module transmitter has detected a fault condition related to

10Gb/s 300m SFP+ Transceiver (10G-SFP-SR) LCConnector, Tx850nm, VCSEL, Multimode

laser operation or safety. The TX_Fault output contact is an open drain/collector and shall be pulled up to the Vcc_Host in the host with a resistor in the range 4.7-10 kΩ. TX_Disable is a module input contact. When TX_Disable is asserted high or left open, the SFP+ module transmitter output shall be turned off. This contact shall be pulled up to VccT with a 4.7 kΩ to 10 kΩ resistor

The receiver converts 10Gbit/s serial optical data into serial PECL/CML electrical data. An open collector compatible Loss of Signal is provided. Rx_LOS when high indicates an optical signal level below that specified in the relevant standard. The Rx_LOS contact is an open drain/collector output and shall be pulled up to Vcc_Host in the host with a resistor in the range 4.7-10 kΩ, or with an active termination. Power supply filtering is recommended for both the transmitter and receiver. The Rx_LOS signal is intended as a preliminary indication to the system in which the SFP+ is installed that the received signal strength is below the specified range. Such an indication typically points to non-installed cables, broken cables, or a disabled, failing or a powered off transmitter at the far end of the cable.

Absolute Maximum Ratings:

Parameter	Symbol	Min	Typ	Max	Unit	Ref.
Maximum Supply Voltage	Vcc	-0.5		4.7	V	
Storage Temperature	TS	-40		85	°C	
Case Operating Temperature	TOP	0		70	°C	

Optical Characteristics:

Parameter	Symbol	Min	Typ	Max	Unit	Ref.
Transmitter						
Output Opt. Pwr	POUT	-6		-1	dBm	1
Optical Wavelength	λ	840	850	860	nm	
Optical Extinction Ratio	ER	3.0			dB	
RIN	RIN			-128	dB/Hz	
Output Eye Mask	Compliant with IEEE 0802.3ae					
Receiver						
Rx Sensitivity	RSSENS			-10	dBm	2
Input Saturation Power (Overload)	Psat	-3			dBm	
Wavelength Range	λ_c	770	850	860	nm	
LOS De -Assert	LOSD			-14	dBm	
LOS Assert	LOSA	-30			dBm	
LOS Hysteresis		0.5			dB	

Notes:

1. Class 1 Laser Safety per FDA/CDRH and IEC-825-1 regulations.
2. with worst-case extinction ratio. Measured with a PRBS 223-1 test pattern, @1.25Gb/s, BER<10-12

Pin Descriptions:

**10Gb/s 300m SFP+ Transceiver (10G-SFP-SR)
LCConnector, Tx850nm, VCSEL, Multimode**

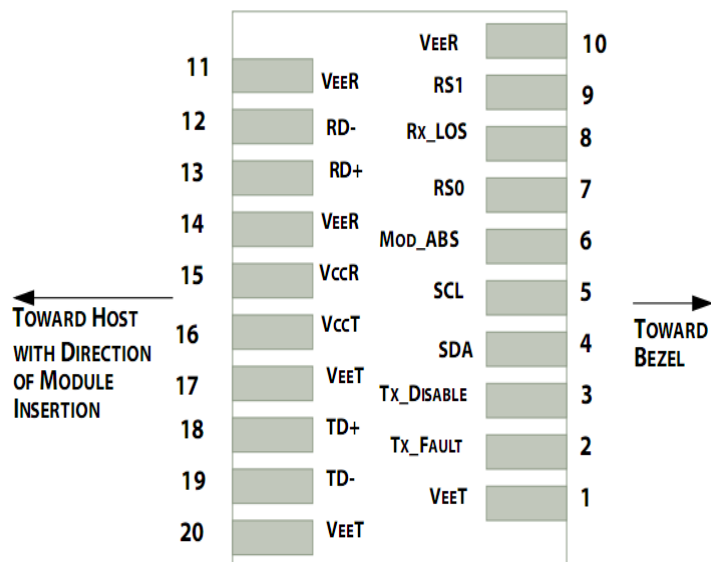

Pin out of Connector Block on Host Board

Pin	Symbol	Name/Description	Ref.
1	V _{EET}	Transmitter Ground (Common with Receiver Ground)	1
2	T _{FAULT}	Transmitter Fault.	2
3	T _{DIS}	Transmitter Disable. Laser output disabled on high or open.	3
4	SDA	2-wire Serial Interface Data Line	4
5	SCL	2-wire Serial Interface Clock Line	4
6	MOD_ABS	Module Absent. Grounded within the module	4
7	RS0	Rate Select 0	5
8	LOS	Loss of Signal indication. Logic 0 indicates normal operation.	6
9	RS1	No connection required	1
10	V _{EER}	Receiver Ground (Common with Transmitter Ground)	1
11	V _{EER}	Receiver Ground (Common with Transmitter Ground)	1
12	RD-	Receiver Inverted DATA out. AC Coupled	
13	RD+	Receiver Non-inverted DATA out. AC Coupled	
14	V _{EER}	Receiver Ground (Common with Transmitter Ground)	1
15	V _{CCR}	Receiver Power Supply	
16	V _{CCT}	Transmitter Power Supply	
17	V _{EET}	Transmitter Ground (Common with Receiver Ground)	1
18	TD+	Transmitter Non-Inverted DATA in. AC Coupled.	
19	TD-	Transmitter Inverted DATA in. AC Coupled.	
20	V _{EET}	Transmitter Ground (Common with Receiver Ground)	1

Notes:

1)Circuit ground is internally isolated from chassis ground.

10Gb/s 300m SFP+ Transceiver (10G-SFP-SR) LCConnector, Tx850nm, VCSEL, Multimode

- 2)TFAULT is an open collector/drain output, which should be pulled up with a 4.7kΩ - 10 kΩ resistor on the host board if intended for use. Pull up voltage should be between 2.0V to Vcc + 0.3V. A high output indicates a transmitter fault caused by either the TX bias current or the TX output power exceeding the preset alarm thresholds. A low output indicates normal operation. In the low state, the output is pulled to <0.8V.
- 3)Laser output disabled on TDIS>2.0V or open, enabled on TDIS<0.8V.
- 4)Should be pulled up with 4.7kΩ - 10kΩ on host board to a voltage between 2.0V and 3.6V. MOD_ABS pulls line low to indicate module is plugged in.
- 5)Internally pulled down per SFF-8431 Rev 4.1.
- 6)LOS is open collector output. It should be pulled up with 4.7kΩ - 10kΩ on host board to a voltage between 2.0V and 3.6V. Logic 0 indicates normal operation; logic 1 indicates loss of signal.

Electrical Interface Characteristics

Parameter	Symbol	Min	Typ	Max	Unit	Ref.
Supply Voltage	Vcc	3.14	3.3	3.46	V	
Supply Current	Icc			250	mA	
Transmitter						
Input differential impedance	Rin		100		Ω	1
Single ended data input swing	Vin,pp	180		700	mV	
Transmit Disable Voltage	VD	Vcc-1.3		Vcc	V	
Transmit Enable Voltage	VEN	Vee		Vee+ 0.8	V	2
Transmit Disable Assert Time				10	us	
Receiver						
Differential data output swing	Vout,pp	300		850	mV	3
Data output rise time	tr	28			ps	4
Data output fall time	tf	28			ps	4
LOS Fault	VLOS fault	Vcc-1.3		VccHOST	V	5
LOS Normal	VLOS norm	Vee		Vee+0.8	V	5
Power Supply Rejection	PSR	100			mVpp	6

Notes:

- 1)Connected directly to TX data input pins. AC coupled thereafter.
- 2)Or open circuit.
- 3)Into 100 ohms differential termination.
- 4)These are unfiltered 20-80% values
- 5)Loss Of Signal is LVTTTL. Logic 0 indicates normal operation; logic 1 indicates no signal detected.
Receiver sensitivity is compliant with power supply sinusoidal modulation of 20 Hz to 1.5 MHz up to specified value applied through the recommended power supply filtering network.

Host-Transceivers Interface Block Diagram

10Gb/s 300m SFP+ Transceiver (10G-SFP-SR) LCConnector, Tx850nm, VCSEL, Multimode

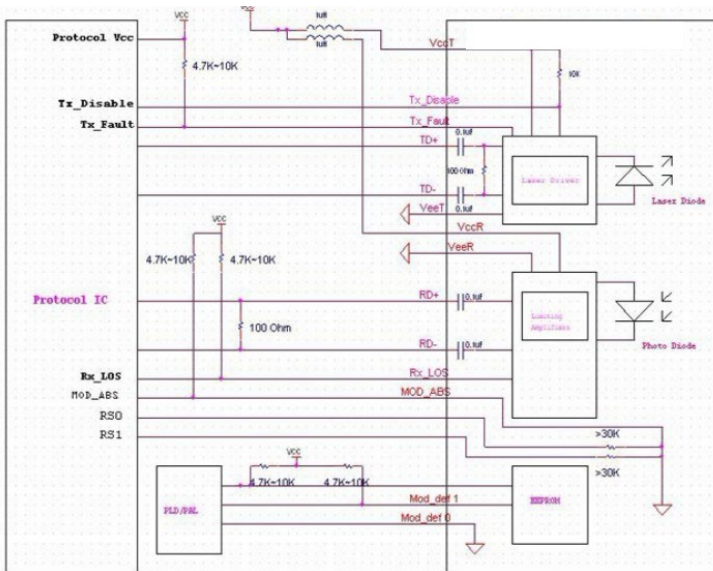

Digital Diagnostic Functions

The 10G-SFP-SR transceivers support the 2-wire serial communication protocol as defined in the SFP MSA1.

The standard SFP serial ID provides access to identification information that describes the transceiver's capabilities, standard interfaces, manufacturer, and other information.

Additionally, Wave Thought SFP+ transceivers provide a unique enhanced digital diagnostic monitoring interface, which allows real-time access to device operating parameters such as transceiver temperature, laser bias current, transmitted optical power, and received optical power and transceiver supply voltage. It also defines a sophisticated system of alarm and warning flags, which alerts end-users when particular operating parameters are outside of a factory set normal range.

The SFP MSA defines a 256-byte memory map in EEPROM that is accessible over a 2-wire serial interface at the 8 bit address 1010000X (A0h). The digital diagnostic monitoring interface makes use of the 8 bit address 1010001X (A2h), so the originally defined serial ID memory map remains unchanged.

The operating and diagnostics information is monitored and reported by a Digital Diagnostics Transceiver Controller (DDTC) inside the transceiver, which is accessed through a 2-wire serial interface. When the serial protocol is activated, the serial clock signal (SCL, Mod Def 1) is generated by the host. The positive edge clocks data into the SFP transceiver into those segments of the EEPROM that are not write-protected. The negative edge clocks data from the SFP transceiver. The serial data signal (SDA, Mod Def 2) is bi-directional for serial data transfer. The host uses SDA in conjunction with SCL to mark the start and end of serial protocol activation. The memories are organized as a series of 8-bit data words that can be addressed individually or sequentially.

Mechanical Specifications:

Comply with SFF-8432 rev5.0, the improved Pluggable form factor specification

10Gb/s 300m SFP+ Transceiver (10G-SFP-SR)
LCConnector, Tx850nm, VCSEL, Multimode

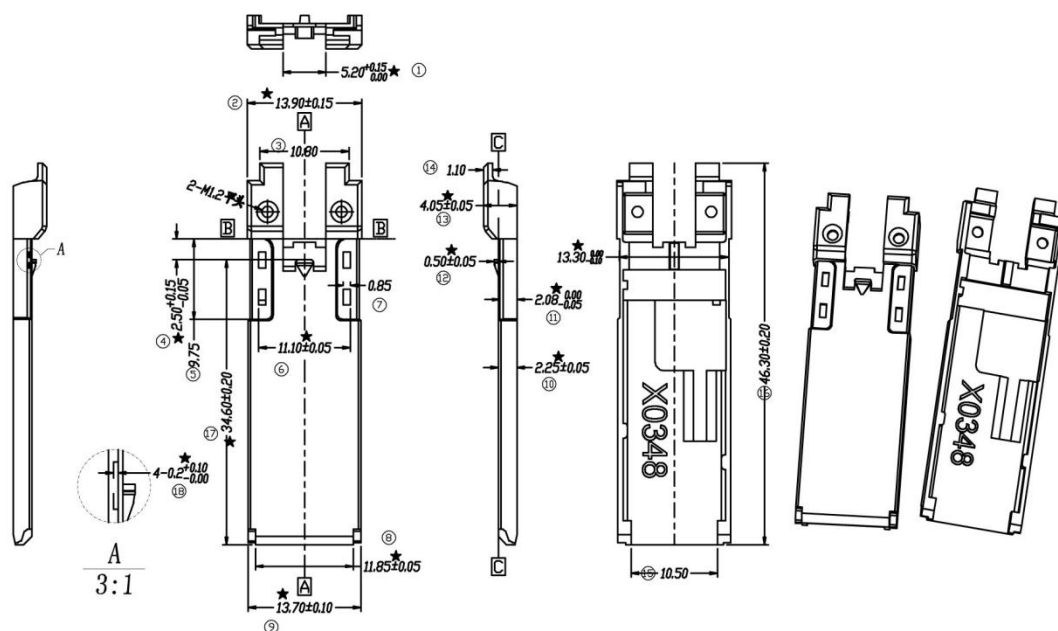

Regulatory Compliance

Feature	Reference	Performance
Electrostatic discharge (ESD)	IEC/EN 61000-4-2	Compatible with standards
Electromagnetic Interference (EMI)	FCC Part 15 Class B EN 55022 Class B (CISPR 22A)	Compatible with standards
Laser Eye Safety	FDA 21CFR 1040.10, 1040.11 IEC/EN 60825-1, 2	Class 1 laser product
Component Recognition	IEC/EN 60950, UL	Compatible with standards
ROHS	2002/95/EC	Compatible with standards
EMC	EN61000-3	Compatible with standards